

DESCRIPTION:
SNAPNRACK, OMNILUG

PART NUMBER(S):
242-10034

UNITS: IN, LB, DEG [MM, KG, DEG] SHEET: 1:1

DOC NUMBER:
SNR-DC-01403

DRAWN BY:
D.RYAN

REV: **A** DATE: **12/18/2023**

SnapNrack®

SUNRUN INSTALLATION SERVICES INC.
225 BUSH STREET, SUITE 1400 • SAN FRANCISCO, CA 94104 USA
PHONE (877) 732-2860 • CONTACT@SNAPNRACK.COM

THE INFORMATION IN THIS DRAWING IS CONFIDENTIAL AND PROPRIETARY. ANY REPRODUCTION, DISCLOSURE, OR USE THEREOF IS PROHIBITED WITHOUT THE WRITTEN CONSENT OF SUNRUN SOUTH LLC.

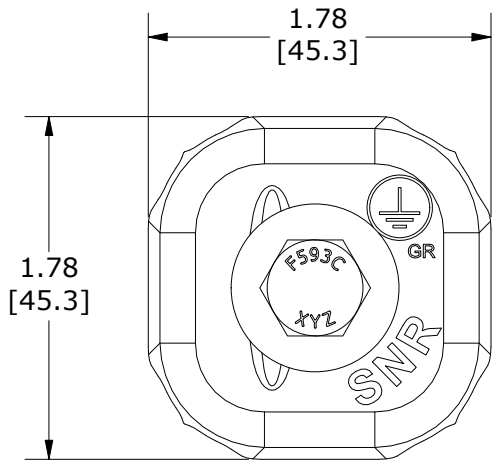

TOP VIEW

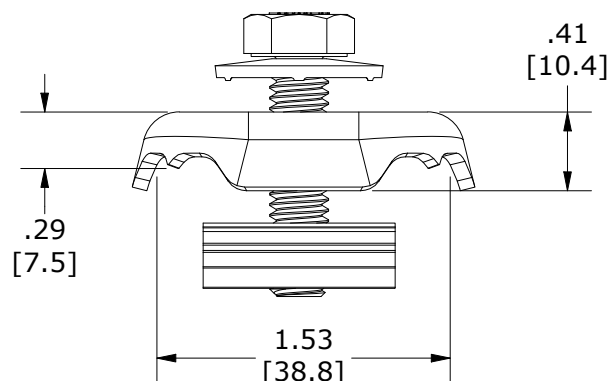

SIDE VIEW

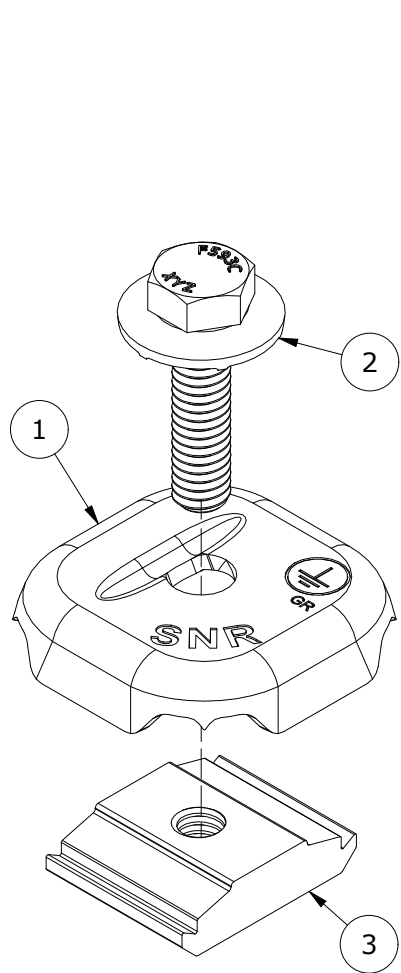

EXPLODED VIEW

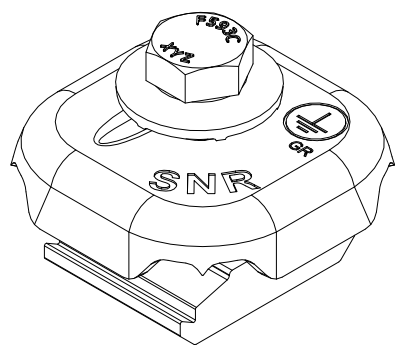

ASSEMBLED VIEW

PARTS LIST		
ITEM	QTY	DESCRIPTION
1	1	SNAPNRACK, OMNILUG, BONDING BRACKET, SS
2	1	SEMS SCREW, HEX, 5-16IN-18 X 1-1-4IN, 7-8 OD CONICAL WSH, TOOTH, SS
3	1	SNAPNRACK, CHANNEL NUT, 5-16IN-18 X 1IN, TALL, NON-BONDING

MATERIALS:	300 SERIES STAINLESS, 6005 AL	OPTIONS:
DESIGN LOAD (LBS):	N/A	SOLID WIRE GAUGE RANGE: 6-12AWG
ULTIMATE LOAD (LBS):	N/A	STRANDED WIRE GAUGE RANGE: 10-12AWG
TORQUE SPECIFICATION:	130 IN-LB	
CERTIFICATION:	UL 467, UL 2703	
WEIGHT (LBS):	0.76	