

Rafter Installation

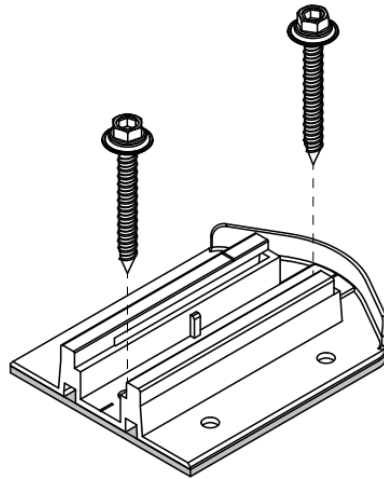

Deck Installation

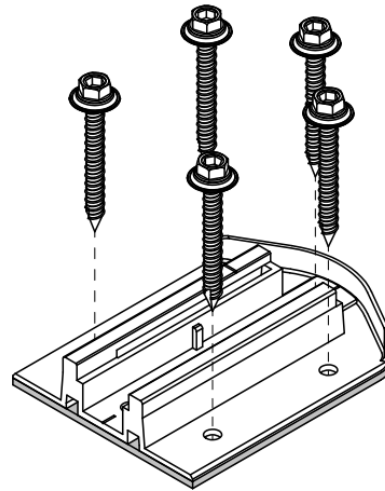

Contents

- Introduction -----
- Periodical Inspection -----
- Tools Required for Assembly -----
- Technical Note -----
- Moisture Content -----
- Installation Safety -----

- PART A: Components -----
- PART B: Bracket Installation -----

- ADDENDUM: Installation Instruction for Metal Roofing
- ADDENDUM: Installation Instruction for Classic rib Metal Roofing
- ADDENDUM: Installation Instruction for Composite Slate
- ADDENDUM: Installation Instruction for Tile

1. Contents

Introduction

Please review this manual thoroughly before installing your Sunstack system. Aside from reading this manual, please review the P.E. Stamped Engineering Letters for the Sunstack Base (SSB1) products for your State. The Sunstack Structural Stamped letters are prepared based on 2 layers of shingles. We recommend the installer to carefully review the instructions provided by the other manufacturers of the products being installed with the Sunstack Base (SSB1) and become acquainted with OSHA's safety procedures prior to installing the PV system.

The installer is solely responsible for:

- Handling and installing the PV modules and rail system according to the manufacturer's instruction, with special attention for the suggested clamping locations on the frame.
- Complying with all applicable local or national building codes, standards and industry best practices including any code that may supersede this manual.
- Ensuring that Sunstack's and other products are appropriate for the particular installation and the installation location.
- Ensuring that the roof, its rafters, connections, and other structural support members can support the array under all code level loading conditions.
- Using only Sunstack parts and installer-supplied parts as specified by Sunstack. (Substitution of parts may void the warranty and invalidate the letters of certification.)
- Verifying the strength of any alternate mounting devices used in lieu of the anchoring screws.
- To maintain the flashing performance, avoid installation when the temperature is below 22F or above 176F.
- Ensuring safe installation of all electrical and mechanical aspects of the PV array.
- PE Stamped letters for the rail option are available at Sunstack website.
- Ensuring correct and appropriate design parameters are used in determining the design loading used for design of the specific installation. Parameters, such as snow loading, wind speed, exposure and topographic factors should be confirmed by the local building official or a licensed professional engineer.
- Sunstack recommends a thermal splice every 15.5 Ft., However, it must be determined by the installer based on the rail system installation instructions. The installer must also determine the maximum allowed span and cantilever design parameters recommended by the rail system manufacturer. The SUNSTACK BASE (SSB1) can be installed on low slope roofs (Metal, EPDM, TPO, SBS, Modified Bitumen/Torch-on, Tar & Gravel, Asphalt) and steep slope roofs (Asphalt shingles, Metal). For low slope roofs, make sure there is positive drainage. SS Butyl is also compatible with felt and synthetic underlayment.

Periodical Inspection

Sunstack LLC. recommends inspecting installed racking system periodically for loose components, loose fasteners and any corrosion. If found, those components are to be re-tightened, or replaced immediately. When a PV module needs to be removed from the PV array for maintenance and/or replacement, the electric bonding system may need to be temporarily restored to maintain the electrical bonding path. Please make sure the system electrical circuits and disconnects are in the open position and the entire system is powered down. Cover the fronts of modules in the array with an opaque material to stop the production of electricity. Use appropriate safety equipment such as insulated tools and insulating gloves to protect yourself.

Maintenance of the PV modules should be carried out by licensed contractors, according to the PV manufacturer's installation/maintenance instructions and Sunstack's installation instructions.

Maintenance should not be conducted under wet and/or high wind conditions.

Tools Required for Assembly

Tools needed for installing the SUNSTACK BASE (SSB1)

- Hex bit (6mm)
10mm socket can also be used for the mounting screws
- Drill and 3 mm Drill Bit or Center punch for sheet metal
(For Installation on Metal Roof)
- Measuring tape
- Chalk line
- Torque Wrench or limiter socket

L-Foot mounting option

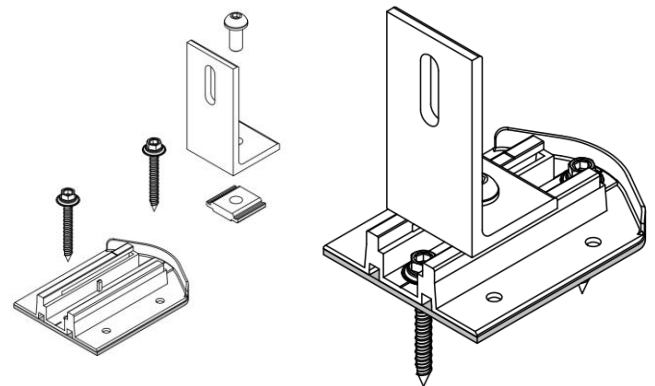

L-Foot mounting option

Item	Torque
SS Slide Plate kit	16 Nm (140 N lb.)

Technical Note

Proper torque values for a wood screw will vary depending on the rafter and/or deck characteristics, hardness, age, and moisture of the wood. Tighten the M6x60mm wood screws until the conical washer stops rotating.

Stainless hardware is soft and if dry torqued too quickly it may cause the nut and bolt to seize. Sunstack recommends all stainless-steel threads be lubricated. This will make it easier to tighten nuts to bolts, avoid galling, and facilitate adjustments before the nut is properly torqued. Therefore, avoid the use of an impact driver.

When driving the M6x60mm or M6x90mm into the wood, always keep a hand pressure on the SUNSTACK BASE (SSB1) to avoid the base being pulled away from the roof surface

Moisture Content

SS Butyl is to be installed on dry mounting surfaces.

Determining how wet is too wet:

First, remove the paper backing from an SUNSTACK product exposing the clean SS Butyl.

Second, press the base, SS Butyl side down against the surface.

Third, pick up the base. If the base adheres to the roof, the roof is suitably dry for installation.

For Metal, EPDM and TPO remove water from the installation area with a cloth or squeegee before placing and affixing the base.

Drying methods: A air blower, heat gun, Sodium Chloride or alcohol is suitable to remove water & ice from most roof surface.

Installation Safety

The installation process requires working on sloped and elevated building surfaces, in outdoor weather conditions, using tools and heavy components designed for the generation of electricity.

- Use properly anchored fall protection equipment. Do not anchor fall protection equipment to roof mounts, or any other inappropriate roof structure.
 - Use caution to prevent objects from falling or dropping off the roof area.
 - Cordon off ground areas directly beneath the roof work area when possible.
 - Always use personal protection equipment such as safety glasses, gloves, etc.
 - Do not perform installation in excessively wet, windy, or inclement weather conditions.
 - When working in hot weather, work crews should take care to prevent symptoms of over-heating or dehydration.
 - Use proper lifting and carrying techniques when handling heavy components at the job site.
- If conditions are challenging for moving PV modules to the roof area, use a mechanical lift.
- Follow best practices when working around high-voltage electrical equipment.

Part A : Components

1. SUNSTACK BASE (SSB1) kit

Item	
A	SUNSTACK BASE (SSB1)
B	Wood Screw M6.0 x 60
C	SS Butyl tape

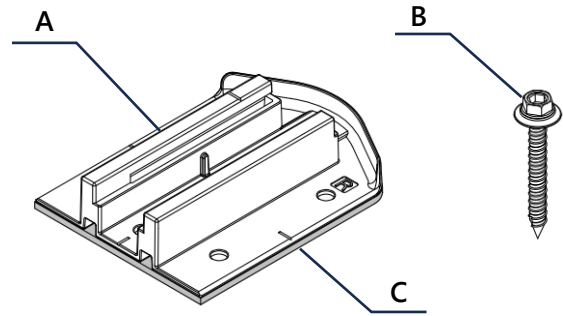

2. (Optional) Wood Screw

Item	
D	Wood Screw M6.0 x 90

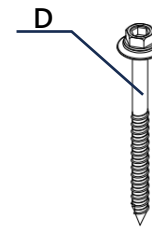

Part B : Bracket Installation

1. Bracket Layout

There is 1 3/16-inch (30mm) adjustability to secure the L-foot kit.

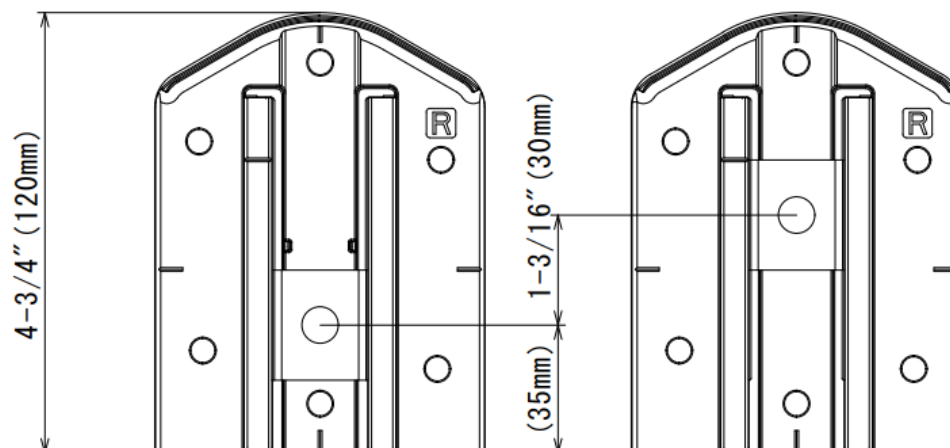

1. Locate and place SSB1 base on the cross section of chalk line.

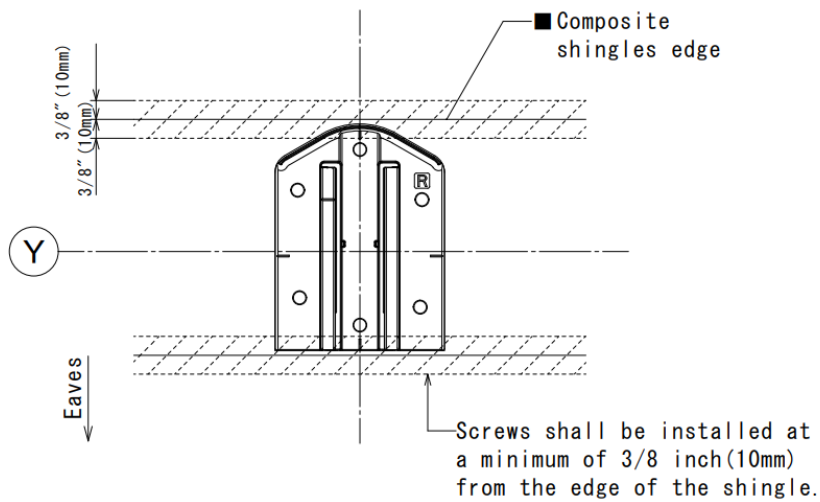

* Note: The SSB1 base is structurally engineered to be mounted in the above position (structural). However, if used to mount accessories such as junction boxes or EMT with no structural value, it can then be mounted in any orientation.

2. Chalk line according to layout plans to indicate bracket's position.

3. Aligning the brackets. Choose the most suitable rafter or deck location, then mark the center.

(i) Line M: Vertical Bracket center line.

(ii) Line Y: Horizontal Bracket center line.

The Engineer of Record (EOR) shall verify the framing capacity and fastener installation for building code compliance including those of the National Design Specification for Wood Construction (NDS 2005/2012/2015) as applicable.

Attention

According to the NDS, the distance from the side edge of the rafter and the 6 mm diameter mounting screws for SSB1 shall be at least 11/32inch (9 mm) from the edge.

Note: Minimum Edge Distance = 1.5D Where D is the Diameter of the screw. Direction of Loading: Parallel to Grain (See NDS 2015 Table 12.5.1c.)

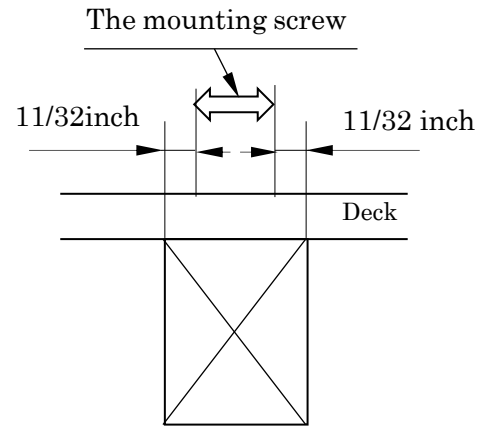

2. SUNSTACK BASE (SSB1) Mounting Option

Rafter Installation

1. Rafter installation (Center) : Fastened in the center to the Rafter with 2 ea. M6.0 x 90mm

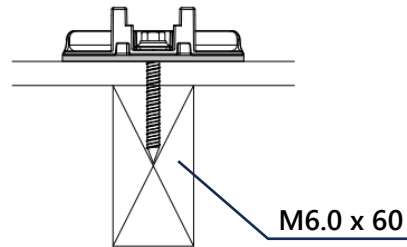
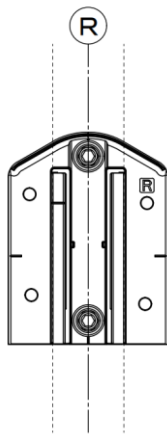

Deck Installation

2. Deck installation: Fastened to the sheathing (Plywood or OSB) with 5ea. M6.0×60 mm wood screws.

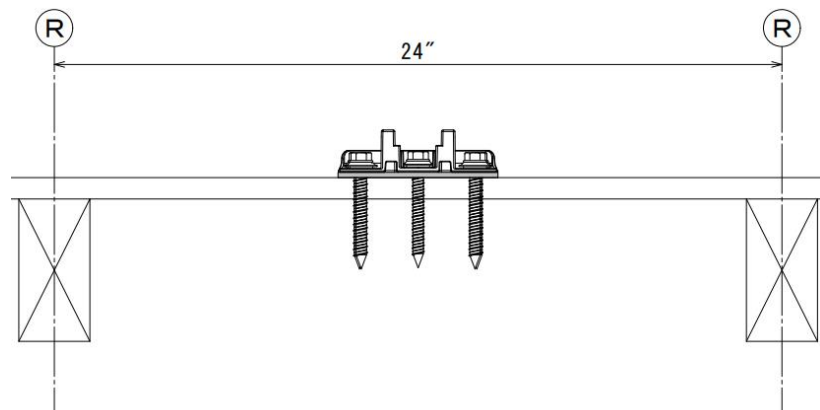
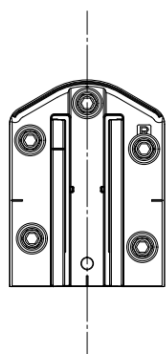

Note: Verify the PE stamped letters for maximum span values.

3. Installation steps

Attention

To maintain the flashing performance, avoid installation when the temperature is below 22F or above 176F. SS Butyl must be installed on a suitably dry surface.

1. Mark the location at the intersection of the Y Line and M Line.

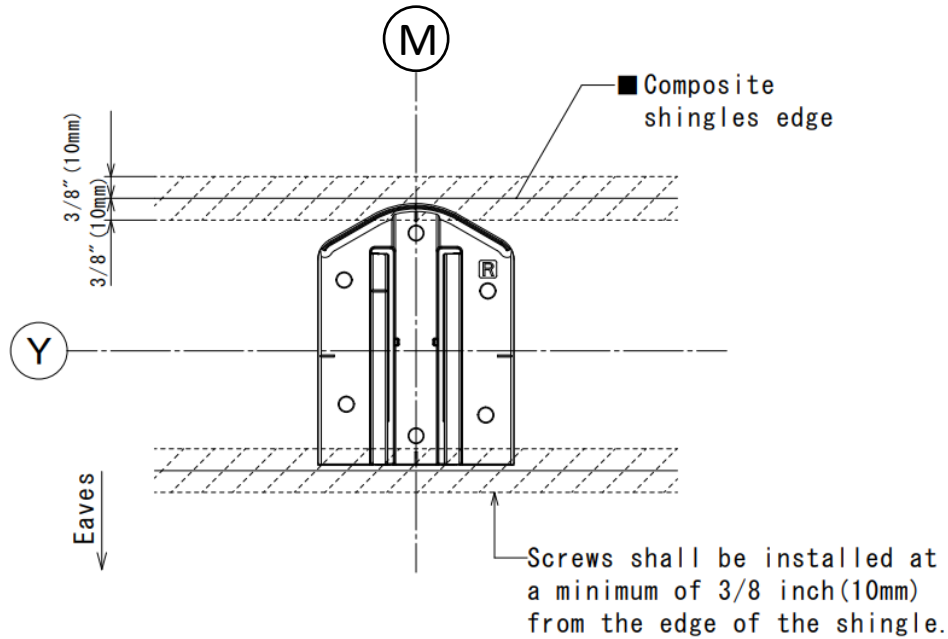

Attention

Minimum clearance between mounting screws and the edge of the roofing shingle shall be 3/8 inch (10 mm).

In case the stainless screw hit the nail underneath the shingle.

- 1) Tip the driver at an angle.
- 2) Use a 3 mm steel drill to make a hole.
- 3) If possible, remove the nail from underneath.

2. Adjust the SS Butyl tape to match the height of the upper shingle. When there is a gap, a slit, or a height difference at the mounting location of the bracket, use additional SS Butyl.

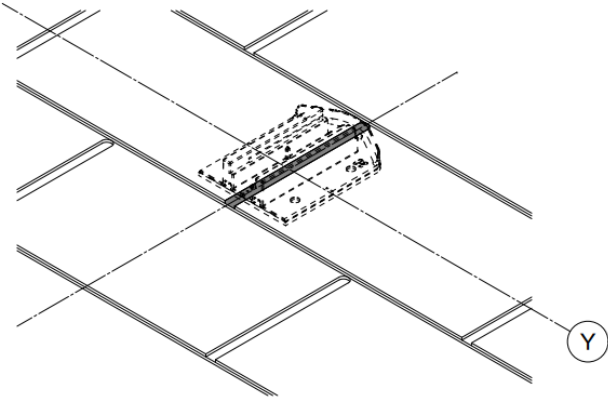

* (for tab shingles only)
When there is a slit at the installation spot, fill in with the additional SS butyl tape. The slit must be filled with SS Butyl.

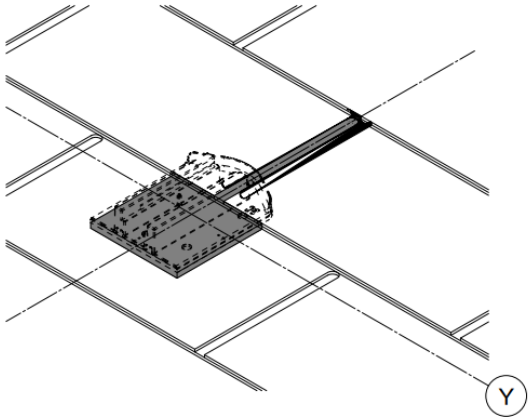

* When there is a slit above the bracket, fill it is with SS Butyl to match its shape

3. If there is a shingle gap (tab shingles only) within 2 inches from the base, sealant or SS butyl shall be applied to the gap as it is shown.

Rafter Installation

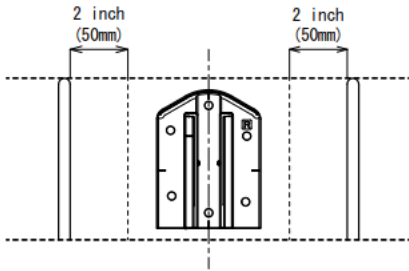

* The best position for the bracket is 2 inches away from the slits.

Deck Installation

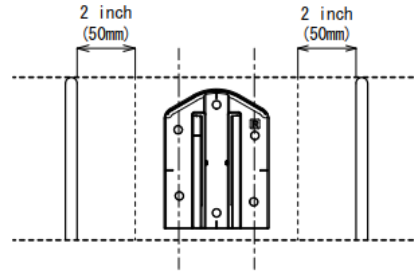

* The best position for the bracket is at least 2 inches away from the slits.

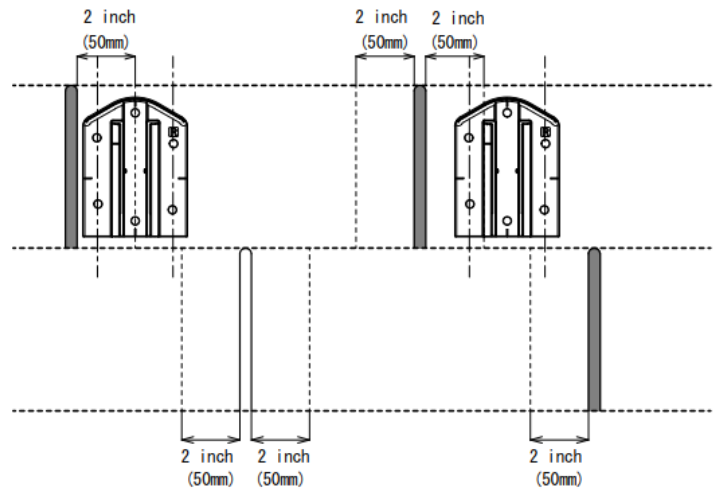
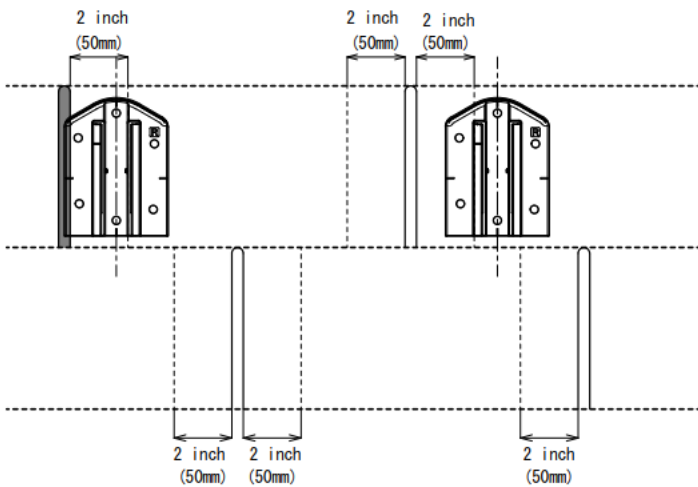

* If the mounting screw is within 2 inches from the slit, fill the slit with roof sealant or SS butyl.

Leveling the Base Option

Case 1

Use SS Butyl to level the surface of the Architectural composite shingle roof.

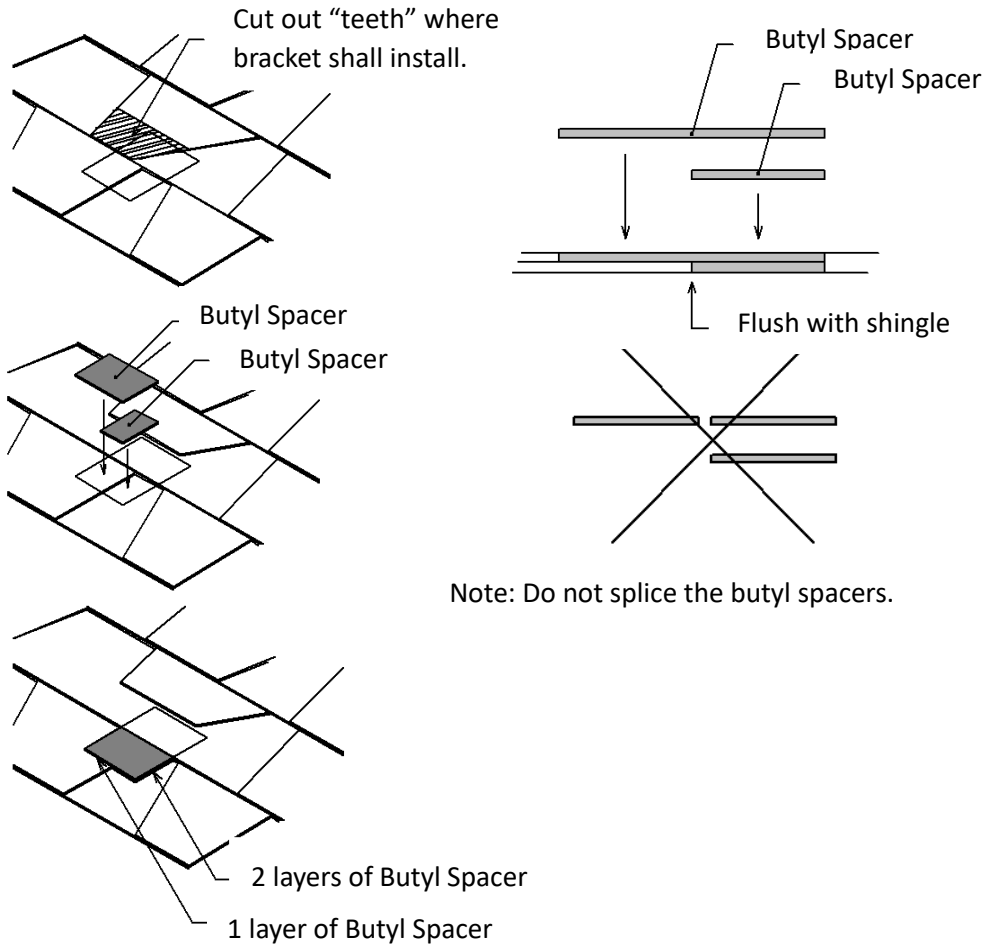

Case 2

The application of one layer of asphalt roofing shim (shingle or shingle starter roll) with the proper asphalt roofing cement is an alternative to leveling when a Sunstack base is to be installed between two levels.

Case 3

Building payers od SS Butyl for the bracket to be mounted over the teeth area of composite shingle roofs.

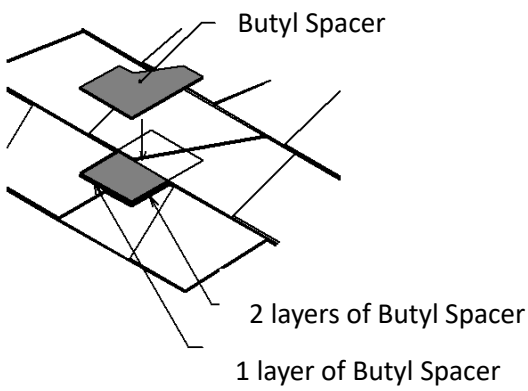
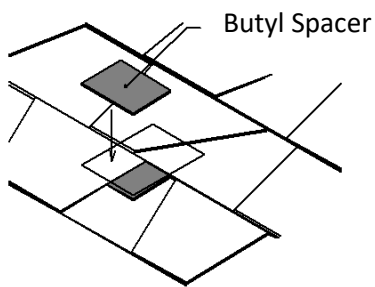
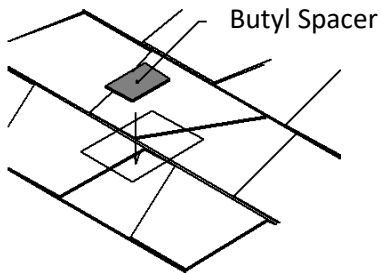

- A maximum of 4 layers is recommended.
- One layer is pre-applied to the bracket.

* The following layers must be cut to the shape to cover the surface of the bracket at each location, assuring a leveled surface.

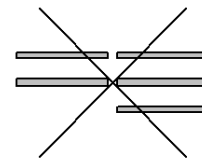
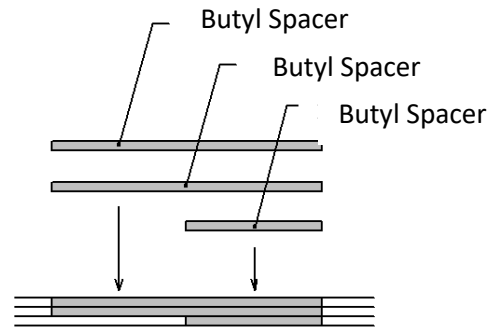

Note: Do not splice the butyl tape.

Note: Do not splice the butyl spacers.

4. Peel off the protective paper from the SS Butyl.

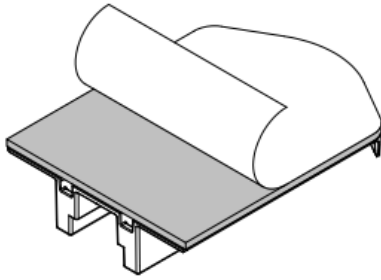

Attention

Do not leave any protective paper on the surface of the SS Butyl, it can cause an improper seal and may allow water intrusion under the bracket.

* Use additional SS butyl to layer/build up the roof material until the surface is leveled.

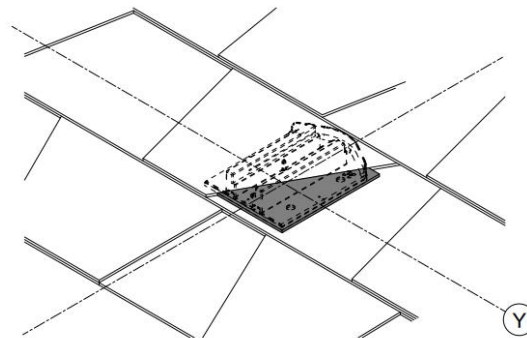

* Note: Each bracket comes with SS Butyl tape installed.

Attention

Peel off the protection paper from both side of any additional SS Butyl.

Attention

Be sure to apply firm pressure when installing the first two mounting screws to endure proper adhesion to the roof.

5. Install Bracket on roof

Rafter Installation

Place the brackets at the specified position and make sure the SS Butyl makes good contact with the roofing surface.

Set the bracket with 2 ea. Screws, M6.0×60 mm stainless wood screw using 6mm hex bit or 10mm socket.

After completing the process, make sure the brackets are securely fixed.

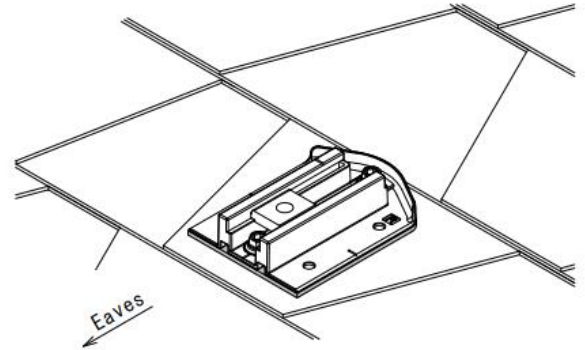
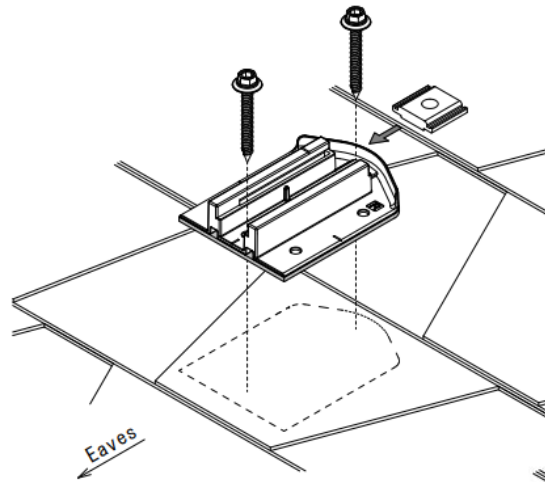

Deck Installation

Place the brackets at the specified position and make sure the SS Butyl makes good contact with the roofing surface.

Set the bracket with 5 ea. Screws, M6.0×60 mm stainless wood screw using 6mm hex bit or 10mm socket.

After completing the process, make sure the brackets are securely fixed.

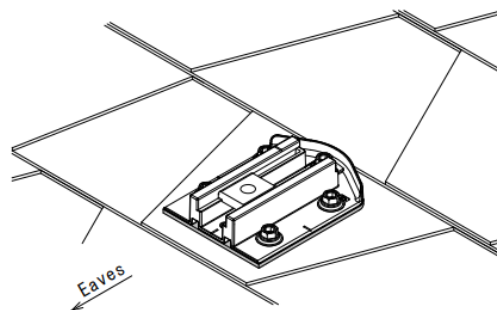
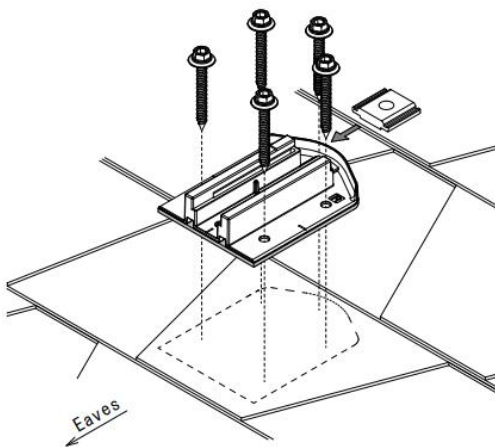

Attention

When the SSB1 base is installed on the deck, 5 screws must be used. Four screws are fixed into the sides and 1 on the center ridge side.

Note: Each SSB1 is shipped with 2 mounting screws.

IMPORTANT

Note: Proper torque values for the 6.0×60 mm screw will vary depending on the rafter and/or deck characteristics; hardness, age, and moisture of the wood etc. It should be tightened until the conical washer stops rotating.

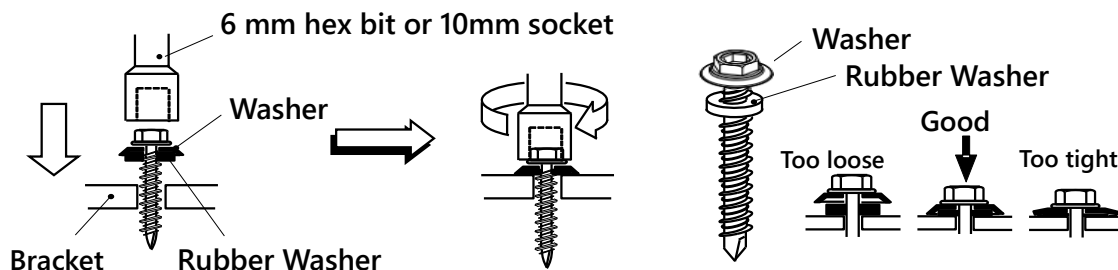

When tightening the screws please tighten all screws equally. Additionally, avoid using an impact driver as it can over torque the screws causing them to strip the threads.

Installation on a Standing Seam Metal Roofing



1. Requirement

- Applicable to maximum 20 gage metal decking.
- The roof should have sheathing (deck) board and the metal roofing should be flat and flush against the sheathing board at least 4-5/16inch (110mm) by 5-1/2inch (140mm) area at the bracket mounting location. The Sunstack P.E. Letters are created for a minimum 7/16" OSB with 2x4" rafters 24 in o.c.

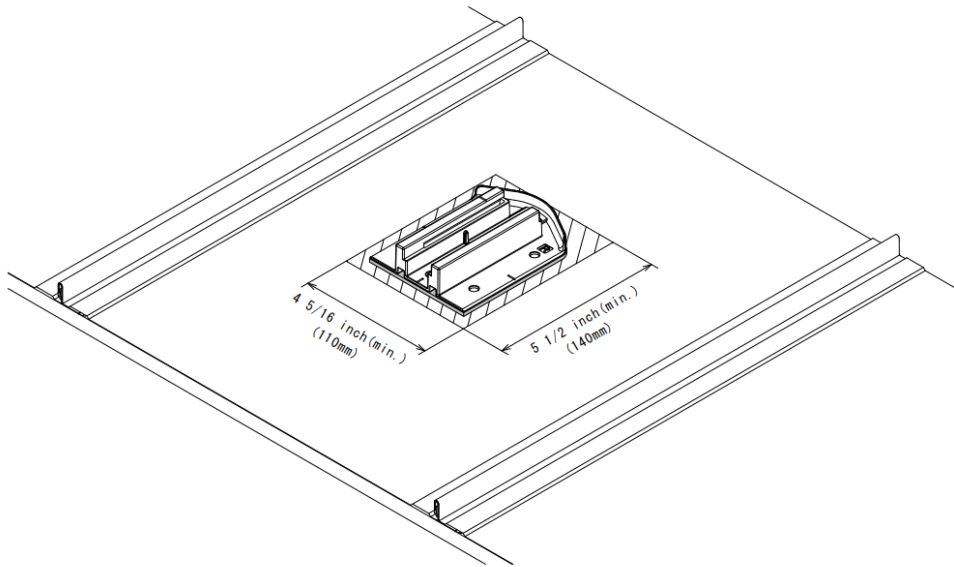

Attention

When the SSB1 base is installed on the deck, 5 screws must be used. Four screws are fixed into the sides and 1 on the center ridge side.

Note: Each SSB1 is shipped with 2 mounting screws. The installer must purchase additional screws when mounting it to the roof deck.

2. Marking on the Roof

(1) Layout

1. Mark at ± 45 mm and 46.5 mm from the intersection of the M line and Y Line. (See illustration)
2. In case of Deck Installation, mark at ± 33 mm and ± 32 mm from the intersection of the M Line and Y line.
3. Then mark at 20, 37, 32, 25 mm from the intersection of the M Line and Y Line.
4. Mark at +35 mm from Y Line and M Line.

Fastening to Rafter

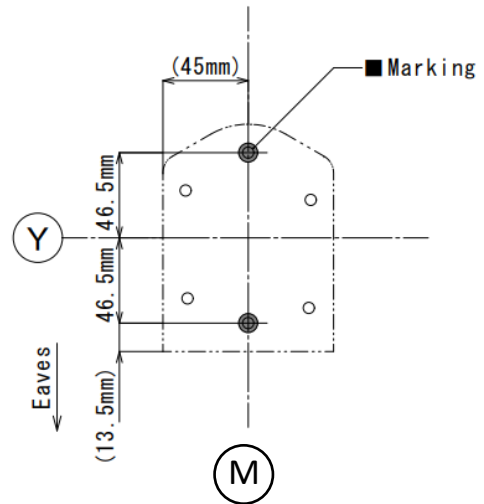

Fastening to Deck

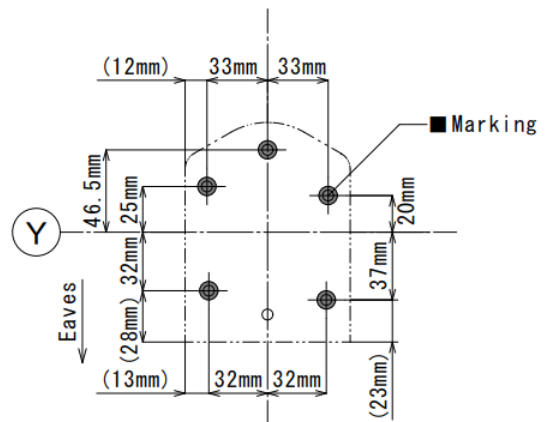

Attention

mounting holes are not symmetric when SSB1 base is installed on deck. You may want to have an extra SSB1 to assist in marking to a metal roof. (Create a SSB1 template by removing the SS Butyl from the base).

3. Bracket Installation

- (1) Drill the roofing metal sheet with a 1/8-inch (3 mm) drill bit at the markings.

Fastening to the Rafter

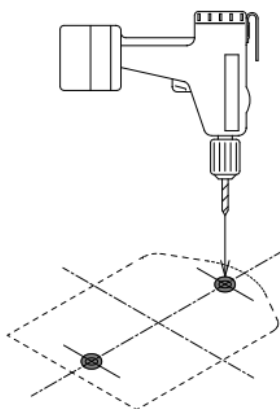

Fastening to the Deck

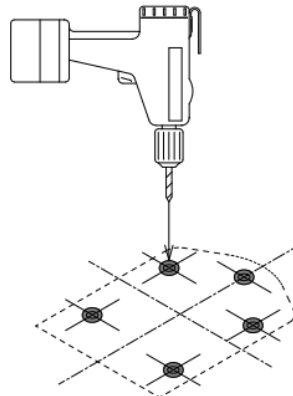

Attention

Be careful to minimize the intrusion of the drill bit into the roof sheathing. Drill only the metal roof.

(2) Use Center punch as an option to make pilot holes. You can mark on roof using measurements, template or use base's screw hole directly from top of the base.

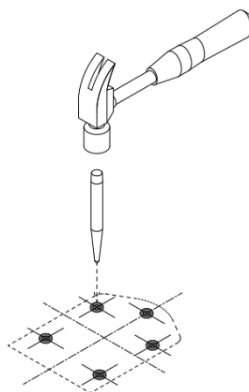

Attention

The "Punching method" can be used for a metal roof with a gap between deck and roof material.

(3) Peel off the protective paper from the SS Butyl.

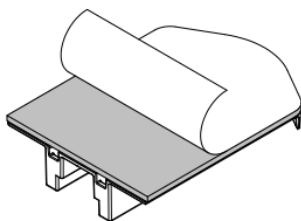

Attention

Do not leave any protective paper on the surface of the SS Butyl as it may cause an improper seal and may allow water intrusion under the bracket.

(4) Place the brackets at the specified location and make sure the SS Butyl attaches well to the roofing surface. Set the bracket with 2 ea. (for RAFTER), or 5 ea. (for Roof DECK), of M6.0×60 mm stainless wood screw using 6 mm hex bit or 10mm socket. After completing the process, make sure the brackets are securely fixed. Fix the attention title.

Fastening to Rafter

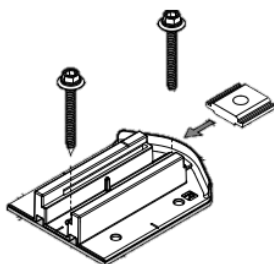

Fastening to Deck

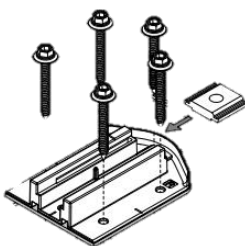

Attention

For deck installation, 5 screws must be used. Four screws are fixed into the sides and 1 on the center ridge side.

Installation on a Classic Rib Metal Roofing

1. Requirement

- The Sunstack P.E. Letters are created for a minimum 7/16" OSB with 2x4" rafters 24 in o.c.

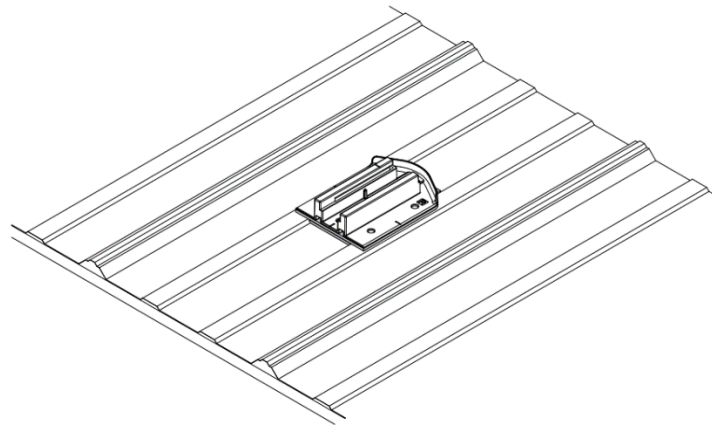

2. Marking on the Roof

Fastening to Deck

(1) Layout

- The SSB1 base must be mounted on the flat surface. Please make sure the location is not on the slope surface of metal ribs.
- For Deck Installation, mark at ± 33 mm, ± 32 mm from the intersection of the M Line and Y Line.
- Then mark at +20, -37, -32, +25 mm from the Y Line.

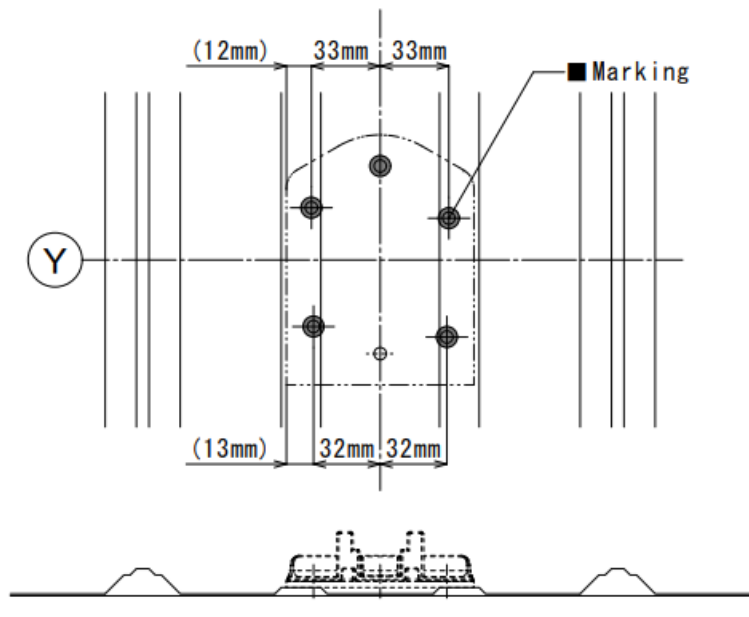

Attention

Mounting holes are not symmetric when SSB1 base is installed on deck. You may want to have an extra SSB1 to assist in marking to a metal roof. (Create a SSB1 template by removing the SS Butyl from the base.)

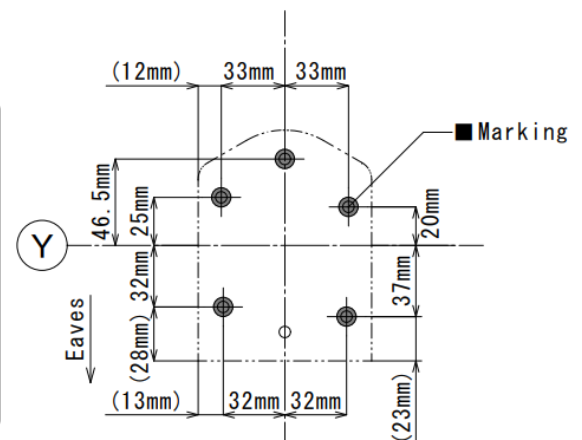

3. Check the height of the metal rib.

(1) The maximum height of the ribs must be 5 mm.

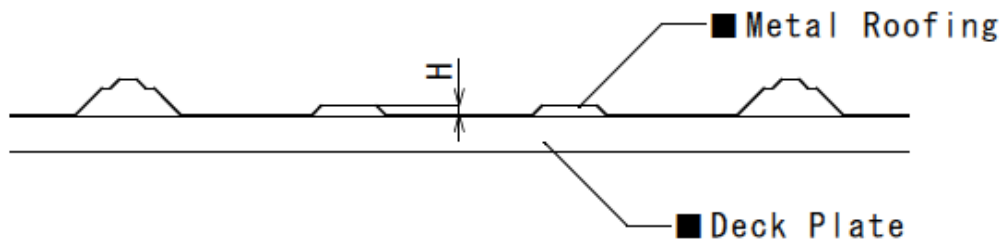

4. Bracket Installation

(1) Please add a SS Butyl spacer on the surface between the ribs.

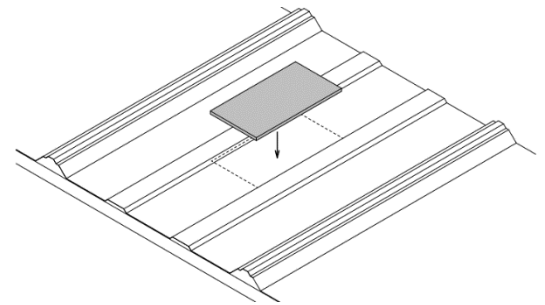
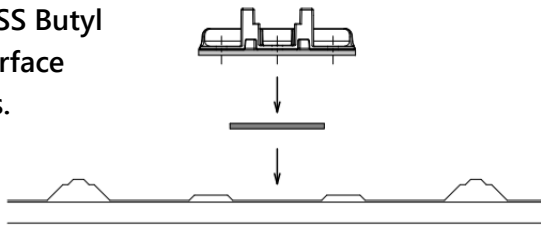

(2) Peel off the protective paper from the SS Butyl.

Attention

Do not leave any protective paper on the surface of the SS Butyl, it may cause an improper seal and may allow water intrusion under the bracket.

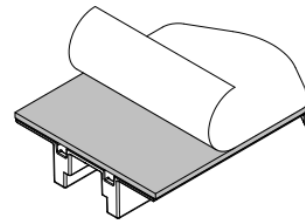

(3) Place the brackets at the specified location and make sure the SS Butyl attaches well to the roofing surface.

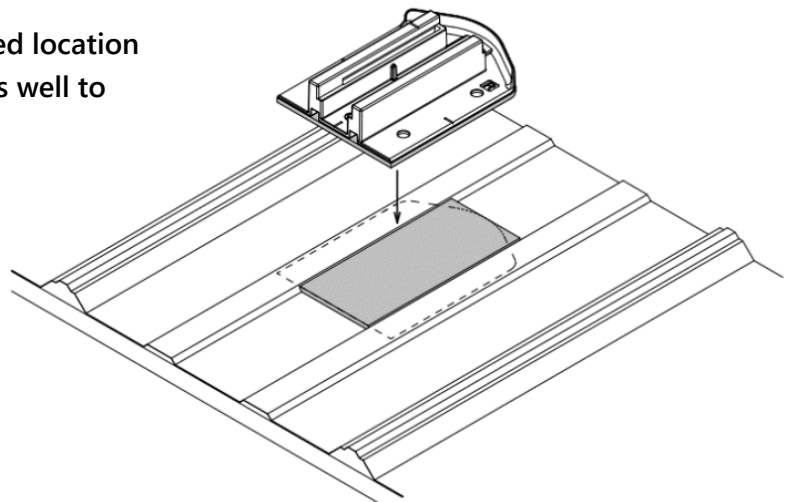

(4) Set the bracket with 5 ea. (For Roof Deck), of M6.0 x 60 mm stainless wood screw using 6 mm hex bit. After completing the process, make sure the brackets are securely fixed.

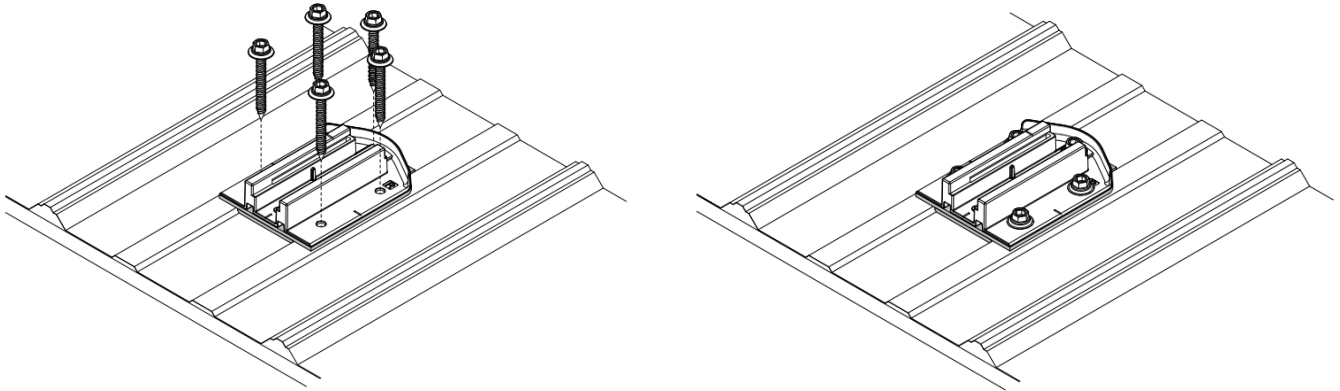

Attention

When the SSB1 base is installed on the deck, 5 screws must be used. The screws are fixed into the side 4 holes and 1 ridge center hole.

Note: Each SSB1 is shipped with 2 mounting screws. The installer must purchase additional screws when mounting it to the roof deck.

Installation on a Composite Tile (Faux Slate & Faux Cedar)

1. Requirement

- Composite Slate must be compatible with SS Butyl

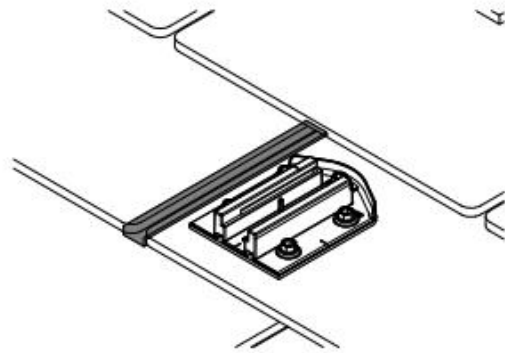

2. Marking on the Roof

(1) Layout

1. The SSB1 base must be mounted on the flat surface.
2. Mark at ± 33 mm and ± 32 mm from the intersection of the M Line and Y Line.
3. Then mark at +20, -37, -32, +25 mm from the intersection of the M Line and the Y Line.

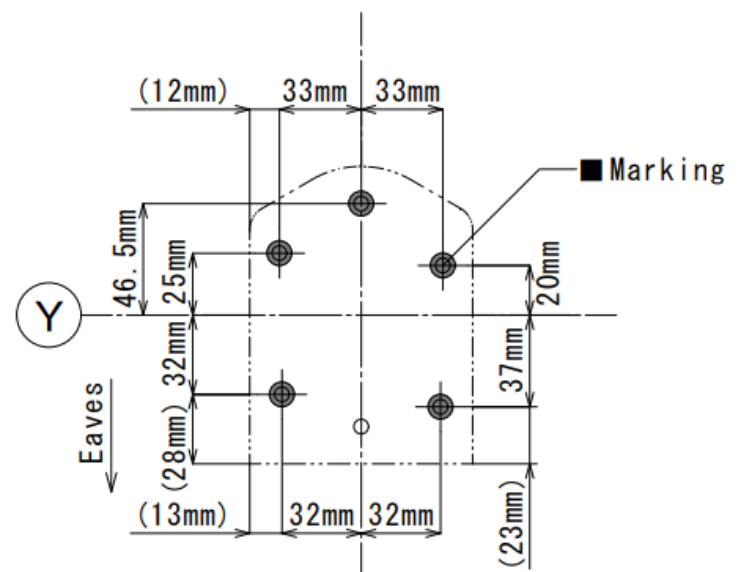

3. Do not drive the M6 x 60 screw on the butyl spacer location. Apply the butyl spacer if the base is installed in the shaded area.

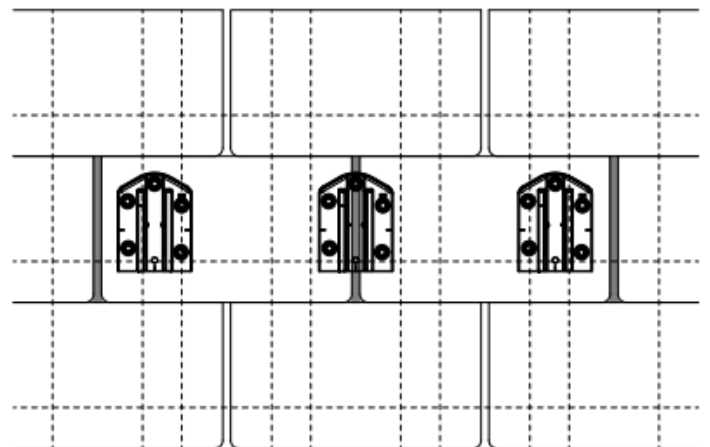
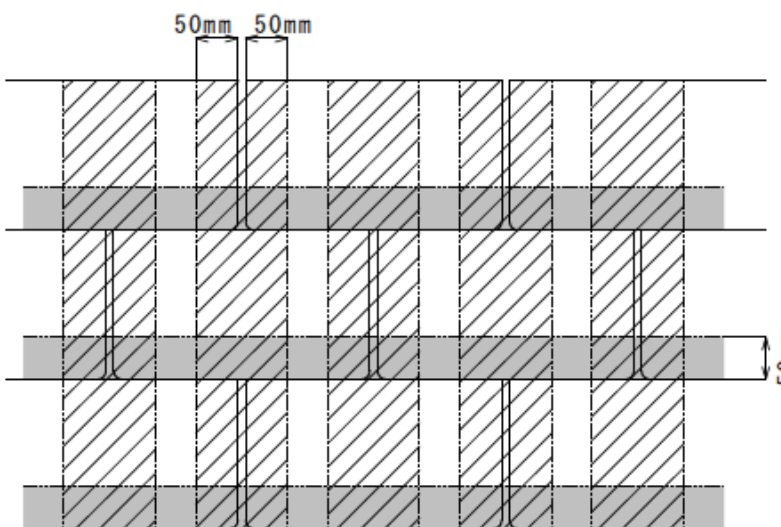

3. Bracket Installation

(1) Drill the roofing metal sheet with a 1/4-inch (6.5 mm) drill bit at the markings.

Note : Avoid drilling through the underlayment!

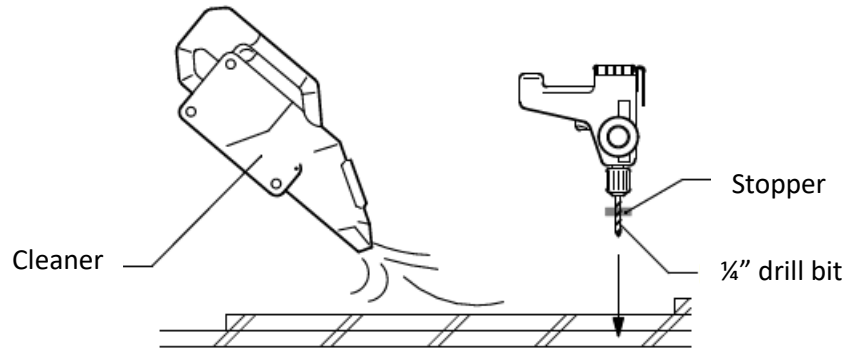

Attention

Installer must avoid drilling into the wood underneath.

(2) Fill the cavity with a sealant listed in this Installation Manual.
The sealant must be flush with the slate surface.

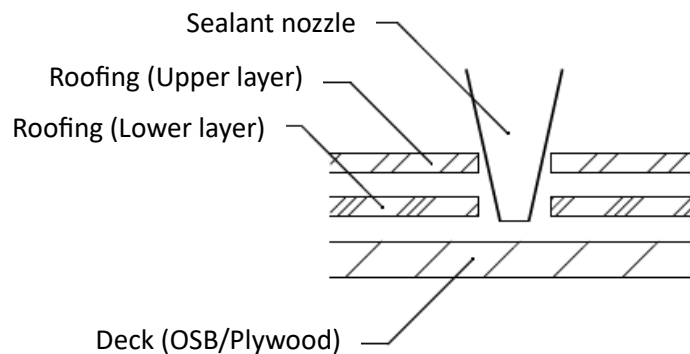

(3) Fill sealant layer by layer. Hold the nozzle in place to ensure lowest layer is filled with sealant displacing all air around the desired attachment point.

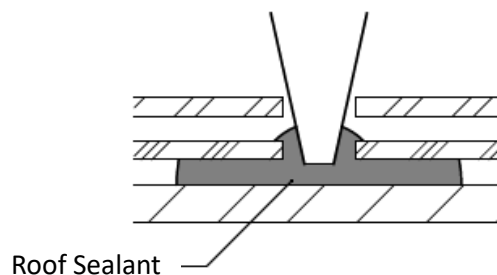

(4) After lower layer is full, move the nozzle back to fill upper layers in the same manner.

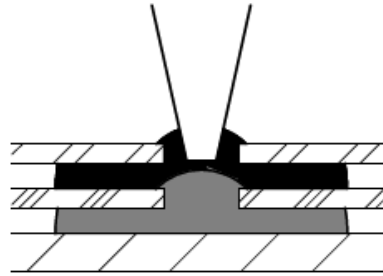

(5) Set the bracket with 5 ea. (For Roof Deck), of M6.0 x 60 mm stainless wood screw using 6 mm hex bit or 10mm socket.

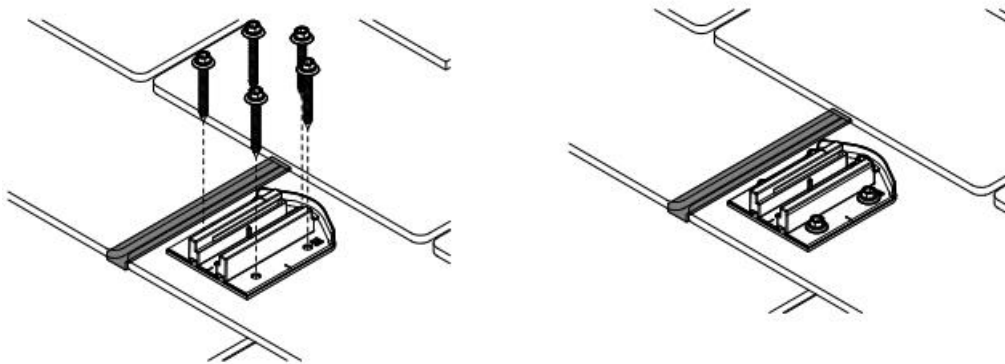

Attention

When the SSB1 base is installed on the deck, 5 screws must be used. The screws are fixed into the side 4 holes and 1 ridge center hole.

Note: Each SSB1 is shipped with 2 mounting screws. The installer must purchase additional screws when mounting it to the roof deck.

Installation on a (S/W/F) Clay Tile Roof

1. Requirement

- Able to install on Deck under the tile roofing.

2. Marking on the Roof

(1) Layout

1. Layout the location of the SSB1 Base.

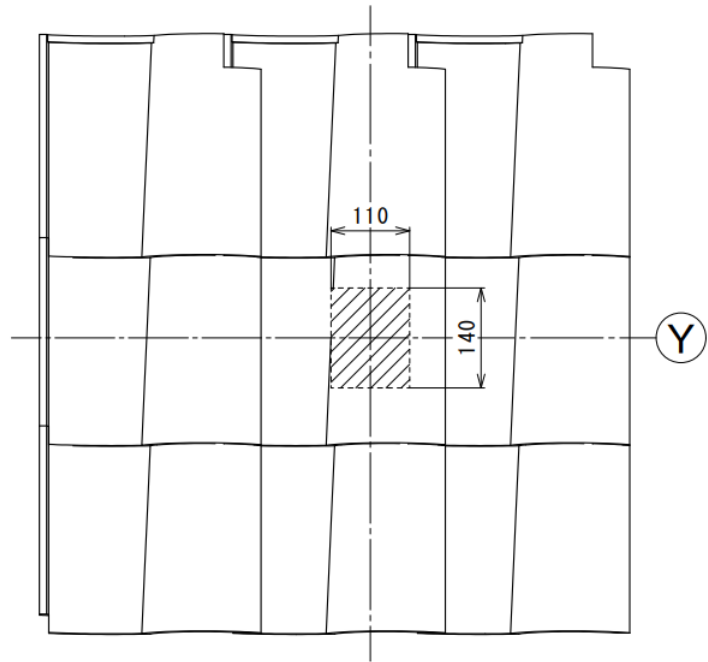

3. Cut out the Tile for Base placement

1. Use Tile cutting tool to open a square hole on the tile.
2. Clean the surface and around the square hole. * Make sure there is no dust or debris around the hole as it may compromise the waterproof seal.

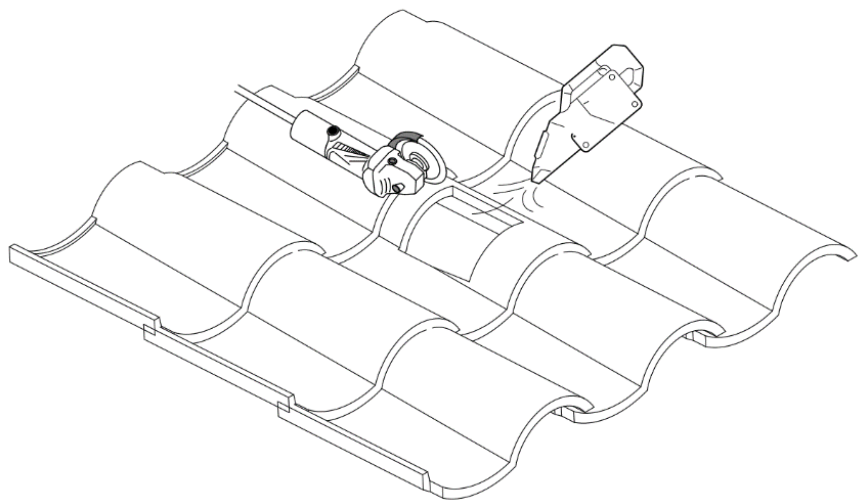

3. Peel off the protective paper from the SS Butyl.

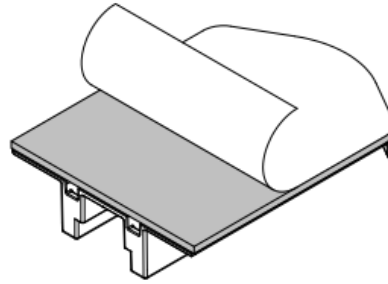

4. Place the brackets at the specified location and make sure the SS Butyl attaches well to the roofing surface. Set the bracket with 5 ea. (for Roof deck), of M6.0 × 60 mm stainless wood screws.

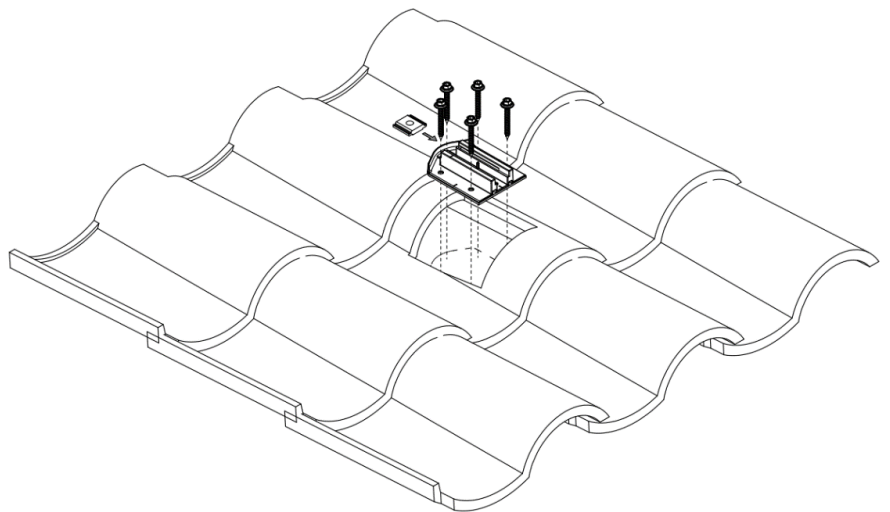
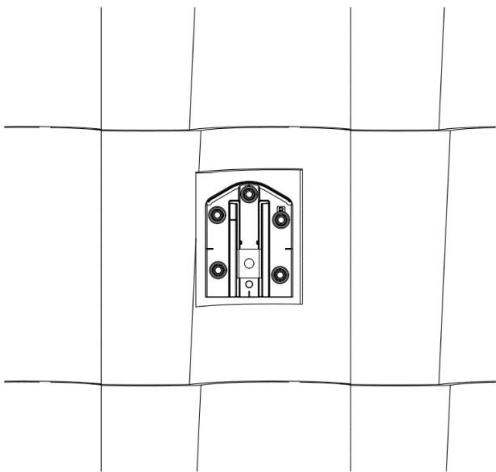

4. Request for PE Report



Please contact to Sunstack team for PE report.

For more information, visit www.sunstackracking.com

2300 West Sahara Ave, Suite 800 Las Vegas, NV 89102 TEL 1-GO-SUNSTACK

